

8ft Alfablocc[®]

| HEIGHT | WIDTH | THICKNESS at base | WEIGHT |
|--------|-------|----------------------|-----------|
| 8'-0" | 4'-0" | 2'-6" | 3850 lbs. |

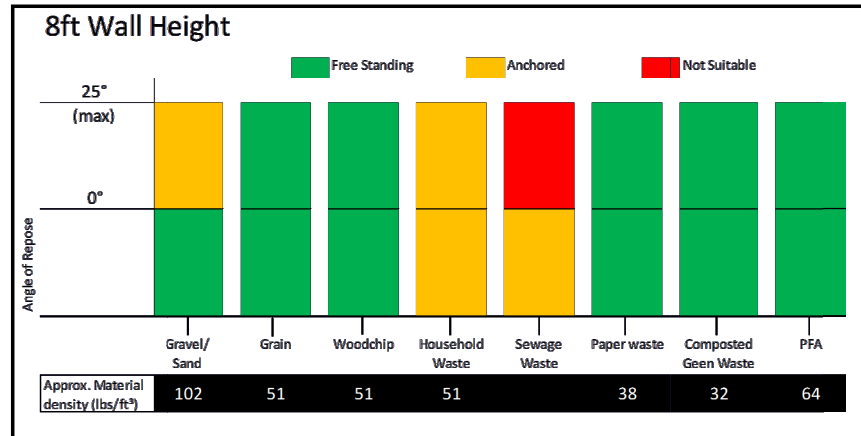

LOADING

REFER TO THE ADJOINING TABLE FOR ANCHORING REQUIREMENTS FOR VARIOUS MATERIALS

THE MAXIMUM ANGLE OF REPOSE IS 25° FOR SUITABLE MATERIALS.

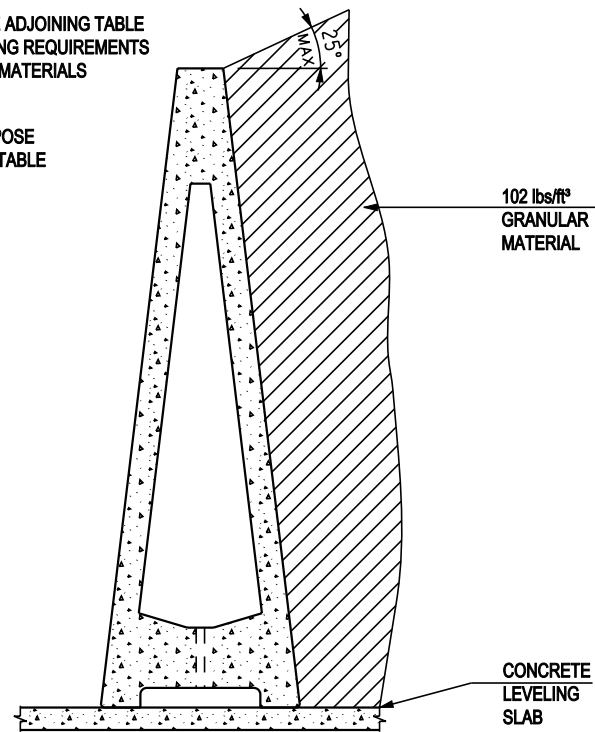

ANCHORING

2-1" DIA. ANCHOR STUDS WITH A MINIMUM EMBEDMENT OF 5½"

THE MAXIMUM ANGLE OF REPOSE IS 25° FOR SUITABLE MATERIALS.

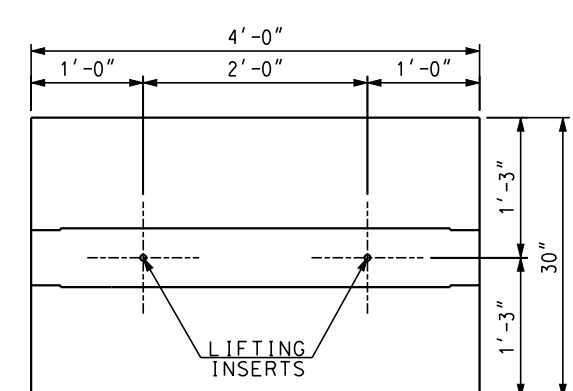
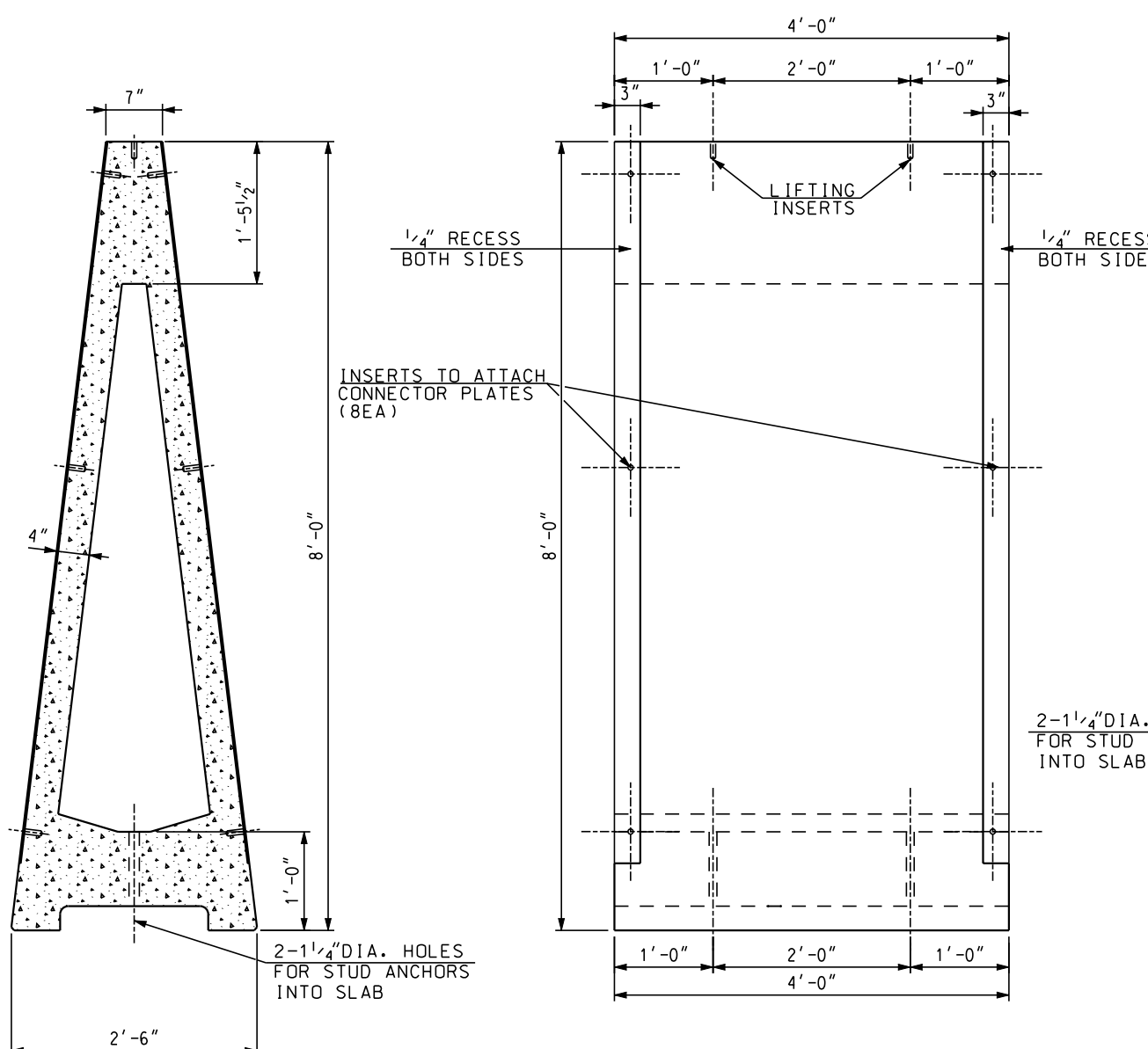
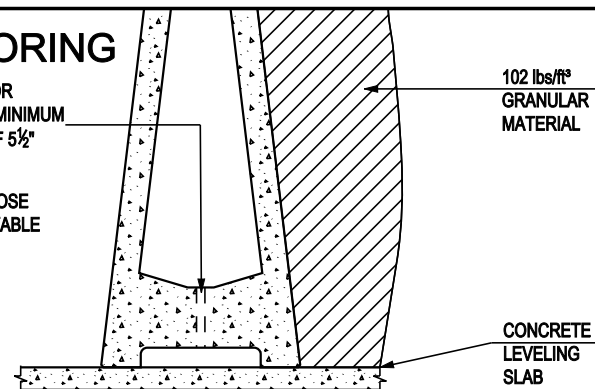

LIFTING INSERTS PLAN

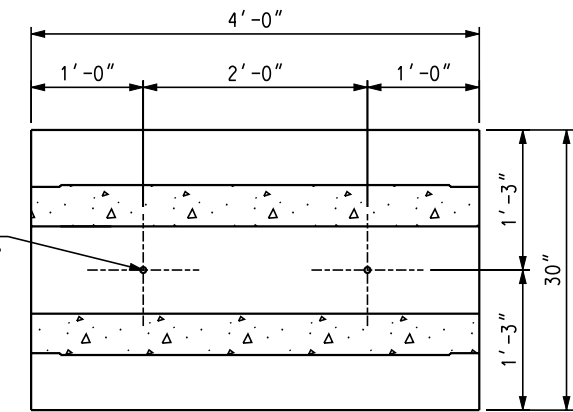

ANCHOR BOLT PLAN